

KOKOS

[English](#)

[Vietnamese](#)

A set of N words is given with the length of each word being exactly $2K$ characters.

A directed graph with each vertex containing a single letter is called a "kokos" if, for each word in the set, there exists a directed path in the graph such that the labels on the vertices along that path form the word. Additionally, for all vertices on that path the following conditions have to be satisfied:

- the in-degree of the first vertex is 0
- the in-degrees of the next $K-1$ vertices is 1
- the out-degrees of the next $K-1$ vertices is 1
- the out-degree of the last vertex is 0

In other words, paths can fork only on the first K letters, and they can meet only on the last K letters. For the given set of the words, we say that the "kokos" is minimal if the total number of vertices is as small as possible.

Write a program that will find the number of vertices in a minimal kokos.

An example of a minimal kokos (the set of the words is from the third example):

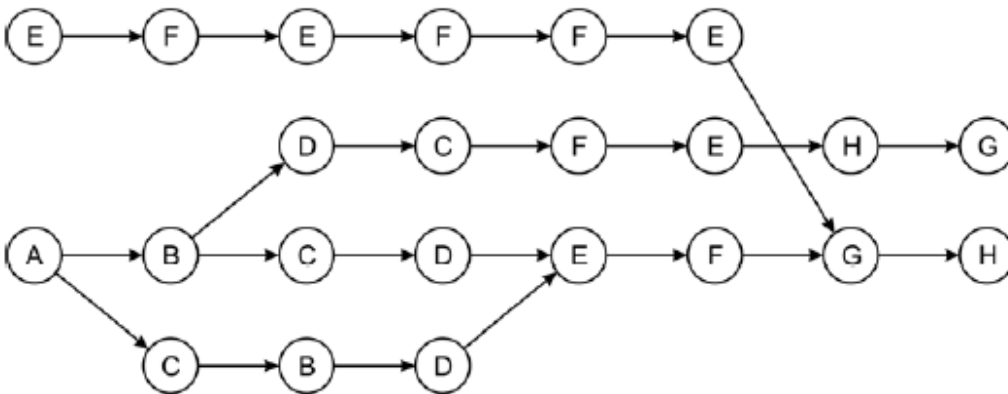

It may seem that we can compact the graph like this:

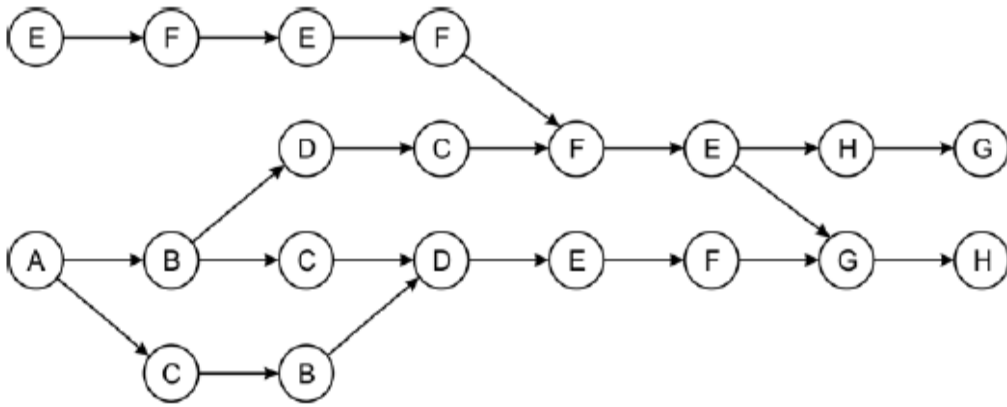

However, this graph is not a kokos because paths meet on the 4th letter (D), and they fork on the 6th letter (E).

Input

The first line of input contains two integers N and K , $1 \leq N \leq 10\,000$, $1 \leq K \leq 100$.

Each of the following N lines contains one word from the set. All letters will be uppercase letters of the English alphabet ('A'-'Z').

Output

The first and only line of output should contain the number of vertices in a minimal kokos.

Sample

input

```
2 4
ABCDEFGH
EFGHIJKL
```

output

16

input

```
4 3
XXZZXX
XXYYZZ
AABBCZ
ABCZZZ
```

output

18

input

```
4 4
ABCDEFGH
ACBDEFGH
```

ABDCFEHG
EFEFFEGH

output

23